

Fiat C.R.42 "Falco"

A/C Type: Short Range Day Fighter
 Engine(s): One Fiat A.74 R1C.38, No F.I.
 Eng. Pwr: 740-840HP Radial, Air Cooled
 A/C Crew: Pilot

Max Speed: 274 MPH at 17,500 Feet
 Max Ceiling: 33,500 / 27,500 / NA Feet

Defense Factor: 5 Size Modifier: +0
 Damage Factor: 6 / 9 Endurance: 120
 Cockpit View: Fair Blind Area: Rear Low

Protection: Cockpit +0 Fuel +0 Engine +0

Climb Decel / Dive Accel: 3.0 / 1.0
 Weight and Load Limit: 440 / 2 - NA

Wpn. Stations	Weight	Allowed Loads
1, 2	220	Bomb, Search Light

Country: Italy

Service Entry Date: May 1939

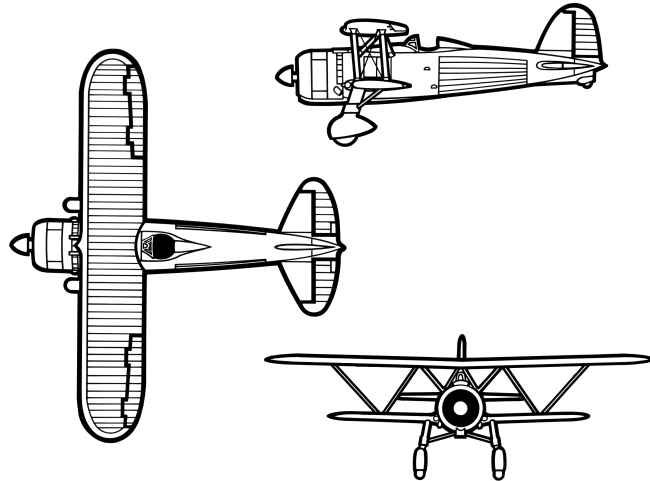

Class: F

Victory Points: 2 - 5

AIRCRAFT PERFORMANCE CHART

Altitude Levels	Band	Minimum Speed	Maximum Speed	Maximum Dive Spd.	Min. TT (1)	Min. HT (2)	Min. BT (2)	Min. ET (3)	Altitude Band	Levels	Average Rate Of Climb
43+	UH	—	—	—	—	—	—	—	UH	43+	—
37 - 42	EH	—	—	—	—	—	—	—	EH	37 - 42	—
31 - 36	VH	2.0	4.0	9.0	3.0	4.5	5.5	6.5	VH	31 - 36	500
25 - 30	HI	2.0	4.5	9.5	3.0	4.0	5.0	5.5	HI	25 - 30	1000
19 - 24	MH	2.0	5.0	9.5	2.5	3.5	4.5	5.0	MH	19 - 24	1700
13 - 18	ML	1.5	5.5	9.0	2.5	3.5	4.0	4.5	ML	13 - 18	2300
7 - 12	LO	1.5	5.0	8.5	2.0	3.0	3.5	4.0	LO	7 - 12	2300
1 - 6	VL	1.5	4.5	8.0	2.0	2.5	3.0	4.0	VL	1 - 6	2400

FIRE POWER CHART

Guns	Type Weapons	Ammo	Criticals
N1	One 12.7mm Breda S.	19	3
N2	One 12.7mm Breda S.	19	3
(or N2)	One 7.7mm Breda S.	19	4

GUN ATTACK FACTORS

Range	N1	N2	(N2)	(Total)
0	7	7	4	14 / 11
1	5	5	3	10 / 8
2	4	4	2	8 / 6
3	3	3	1	6 / 4
4	2	2	1	4 / 3
5	1	1	1	2 / 2
6	1	1	—	2 / 1
7	—	—	—	—

WEAPON STATIONS

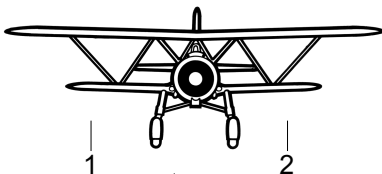

POWER VERSUS SPEED CHART

Levels	Band	1.0 - 4.5	5.0 - 7.5	8.0 - 9.5	10.0 +	Band
43+	UH	—	—	—	—	UH
37 - 42	EH	—	—	—	—	EH
31 - 36	VH	1	—	—	—	VH
25 - 30	HI	2	—	—	—	HI
19 - 24	MH	4	1	—	—	MH
13 - 18	ML	5	2	—	—	ML
7 - 12	LO	6	3	—	—	LO
1 - 6	VL	6	—	—	—	VL
Banking FPs:		1	1	3	5	
Side Slip FPs:		1	2	4	6	

NOTES & VARIANTS

Fiat C.R.42: Maximum attainable level speed -1.0 is always its combat cruise speed regardless of altitude or load. Structurally robust, stressed to 14G, therefore no risk of wing spar damage for ET turns (unless spar damaged by combat, then normal rules apply). No radios. No landing flaps. Fire extinguisher in engine which may be discharged once in event of engine fire (+3 to next "fire" die roll). Some 1939 models delivered with one 12.7mm and one 7.7mm gun. Use N2 in () and firepower totals after slash.

Fiat C.R.42C.B.: Spring 1942 fighter-bomber variant with stations 1 & 2 for a 110lb. or 220lb. bomb each (most converted from existing C.R.42s).

Fiat C.R.42C.N.: October 1941 night-fighter variant with exhaust dampers, a radio, and search lights on stations 1 and 2.